

Excalibur 3S

KEENCUT
THE WORLD'S FINEST CUTTING MACHINES

The perfect cutter for tough sheet materials

Consistent, accurate and efficient cutter for tough rigid boards for the cost conscious, regular user.

- Cuts heavy-duty materials easily
- Consistent perfect cuts
- Precision engineered for accuracy
- Includes three tools as standard
- No dust, debris or static build up
- Quick payback through reduced waste and cutting time
- Safety by design
- Simple intuitive operation
- Manufactured with premium quality materials
- Guaranteed for 5 years

Available in one size to cut materials up to 160cm (63")

Perfect for cutting ...

Semi-rigid materials

- PVC foam board up to 13mm
- Corrugated/fluted plastic (Correx) up to 13mm
- Foam centred board up to 13 mm
- Most other semi-rigid plastic materials
- Magnetic sheet up to 4mm

Rigid materials

- Aluminium composite (Dibond) up to 3mm
- MDF up to 3mm
- Cast acrylic or Plexiglas scoring up to 3mm

If your material is not in the list above we offer a free test cut service - for details please email al.boese@bindrite.com

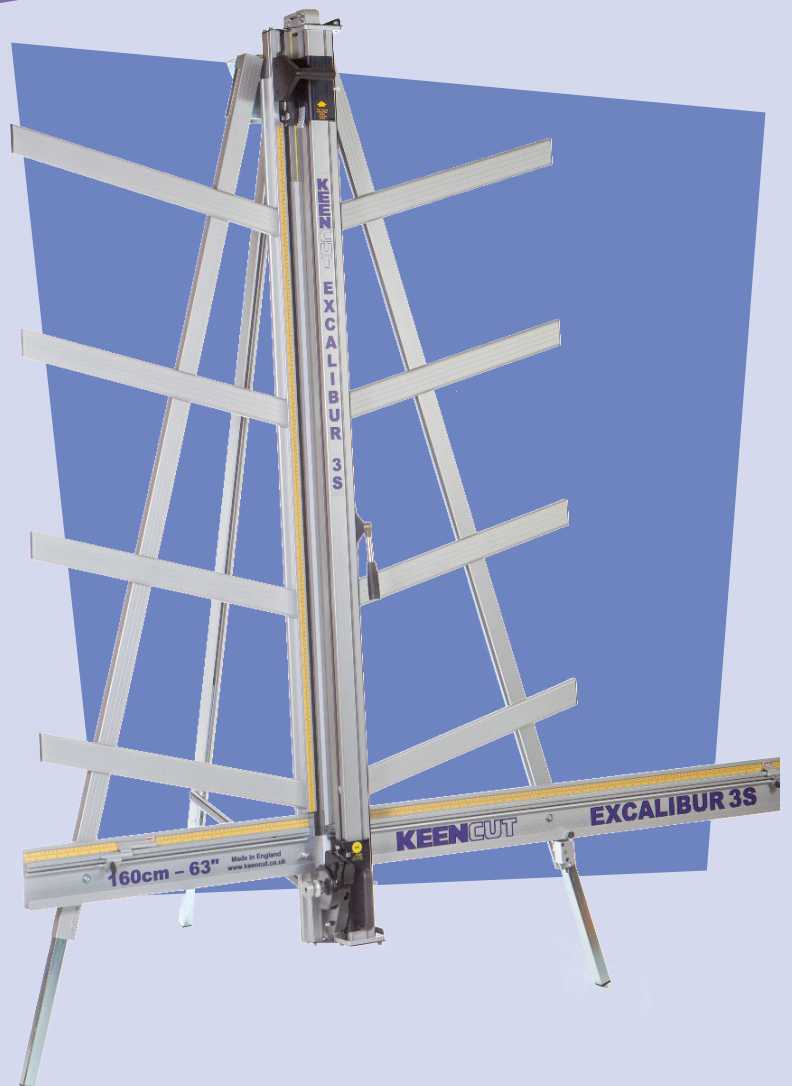

KEENCUT

Baird Road
Willowbrook Industrial Estate
Corby, Northants, England
NN17 5ZA, United Kingdom

Please contact: Al Boese
Ph: 847 283 0970
al.boese@bindrite.com

Cost-effective solution

Double tool head

- Cutting blade and scoring blade permanently mounted for instant use.
- Uses off-the shelf-blades - no costly specialist blades required.



Cut heavy-duty materials

Twin wheel cutter for tougher materials including Dibond and MDF

- Cuts 3mm Dibond or 3mm MDF in a single pass producing a clean, safe edge.
- Noiseless and dust-free.



Consistent perfect cuts

Unique pressure sensitive clamp

- Powerful clamping holds tough materials precisely for a perfect cut.
- Touch-sensitive control clamps delicate or printed materials gently without damage.

Perfect alignment - no fuss

- Keencut's sightline strip gives total accuracy with a single cut line.
- No set-up. No adjustment. No unpredictable, expensive lasers.



Safety by design

- Automatic blade disengagement.
- Blades securely mounted with a safety lock.
- Counterbalanced cutter head.



Simple operation

Telescopic legs for height adjustment to reduce user fatigue.

Quick set production stops to achieve the same cut every time.

Cutting tools permanently fitted for quick engagement.



Engineered for accuracy

- Precision system for fast 90-degree squaring on initial set-up.
- One-piece horizontal squaring arm to provide perfect alignment and rigidity either side of the cut line.

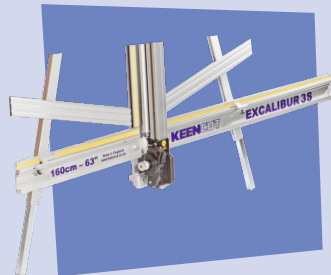

OPTIONAL EXTRAS AND ACCESSORIES

Free standing kit

Ideal for when wall space is limited or flexibility of machine placement is required. Bolts directly to the back of the machine to produce a rigid and stable free-standing unit



DIMENSIONS

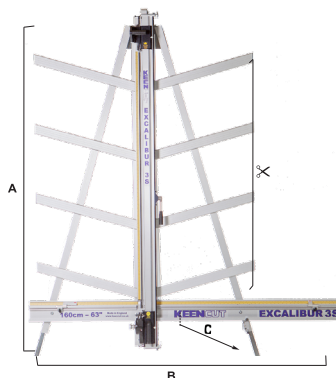

	EX3S165
Cut Length	160cm (63")
A	244cm (96")
B	213cm (84")
Wall Mounted - Standard - C	30-40cm (12-36")
Free Standing - Optional - C	80-90cm (32-36")
Packed Weight	67kg (147lbs)
Packed Dimensions	1 Box Only: 231x40x30cm (91x16x12")



Keencut products have a reputation throughout the world as the most accurate and durable cutting machines on the market. We manufacture from the finest materials and with the latest technology to ensure the highest quality and reliability.

Please contact: Al Boese
Ph: 847 283 0970
al.boese@bindrite.com