

1630

(PNEUMATIC)

Flatbed Applicator for Rigid & Flex Media



The fully equipped multipurpose applicator that gives you access to the superior production method. Its unique tilted table can reduce shipping costs and make entering doors easier. Fast assembly and easy operating.

Click to Watch Video

Laminating a Board Laminating Vinyl

Features



Tilted table for easier entrance and cost saving

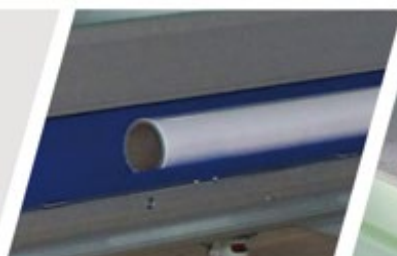

Side trays easily store media and provide capability to apply large format banners etc.

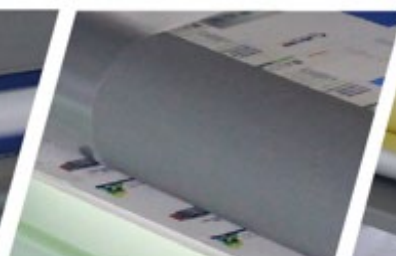

Our 130mm diameter silicon roller has a long lifetime and can meet different laminating and mounting requirements

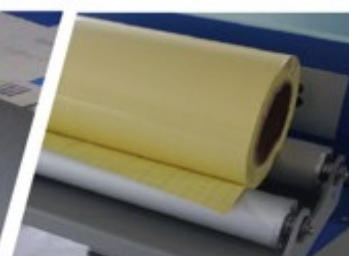

Media holder at the end of the table

Machine Size

	(in metres)	(in inches)
Max lamination width	1.6m	63"
Max lamination length	3m	118.11"
Max working thickness	0.05m	2"
Total table length	3.86m	152"
Total table width	2m	79.13"
Total table height	1.14m	44.88"
Glass thickness	0.01m	0.39"
Roller	Silicon (0.13m dia)	
Up and down	Pneumatic	
Safety glass	Yes	
Working type	Manual	
Heated	None	
Side tray	Optional	

Operation

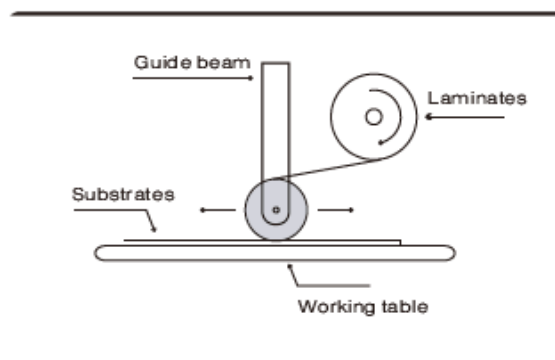

Packing information:

Machine size: 153" (Length) x 45.27" (Width) x 84.64" (Height)

Tilted Table size: 38" (Width)